

Titan
MANUFACTURING, INC.

9447 BAMBOO ROAD, HOUSTON,
TEXAS, 77041.
PHONE: 713-283-7700. FAX: 713-283-7600.
Email: sales@titanpumpsinc.com
Website: www.titanpumpsinc.com

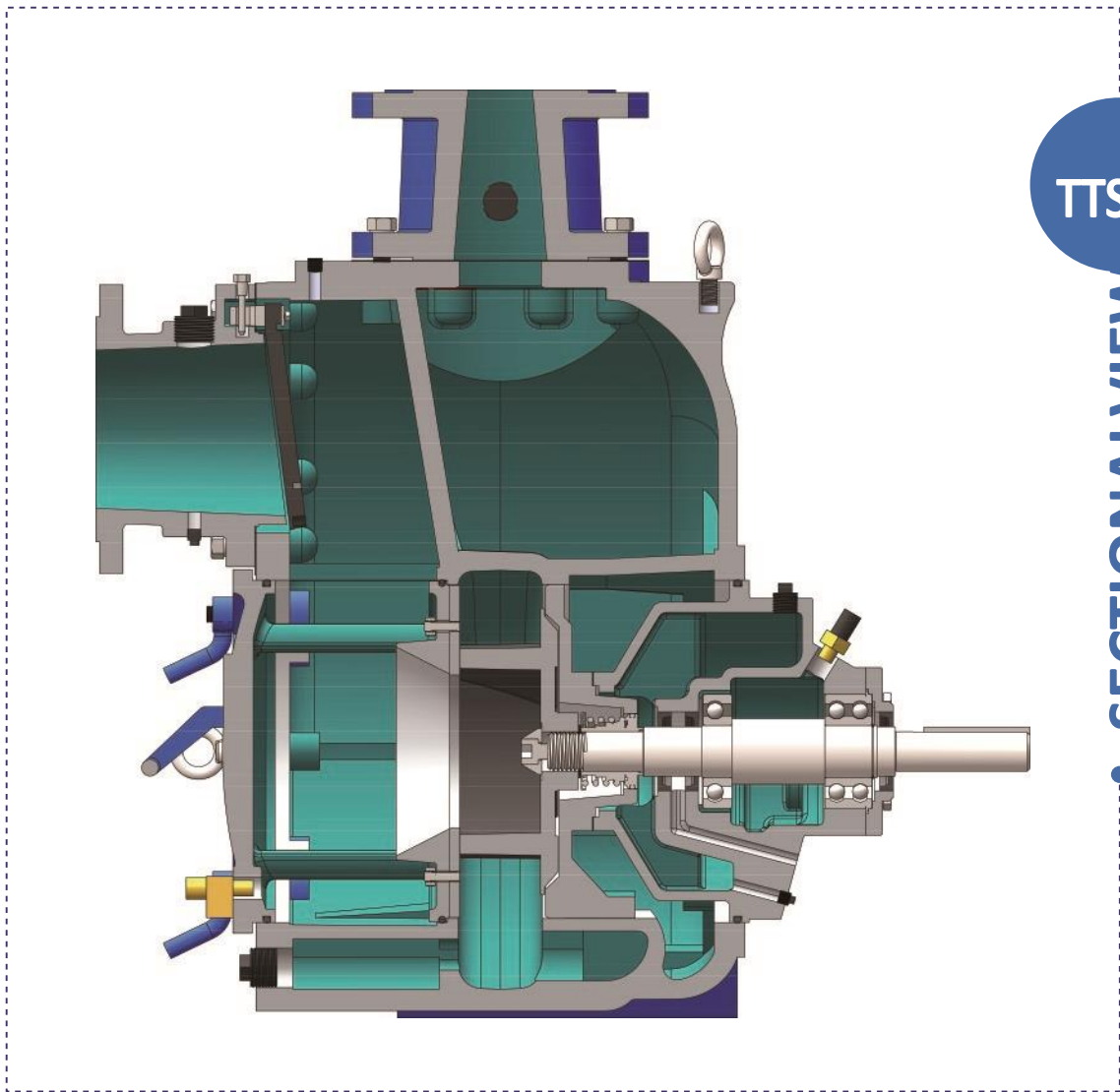

TTSTP SERIES SELF PRIMING TRASH PUMP



PRODUCT FEATURES

TTSTP series pumps are designed for economical, trouble-free operation, the superior solids handling capabilities of the pump make it ideally suited for a variety of applications including solids-laden liquids and slurries. The impeller, seal, wears plate and flap valve can all be accessed through the cover plate opening for inspection or service. Atmospheric barrier along with a lip seal provide additional protection of bearings, also allows external monitoring. Cartridge mechanical seal is specifically designed for abrasive and or trash handling service. The entire rotating assembly can be removed without disturbing pump volute or piping.

▼ OUTLINE DIMENSIONS [Unit: mm]

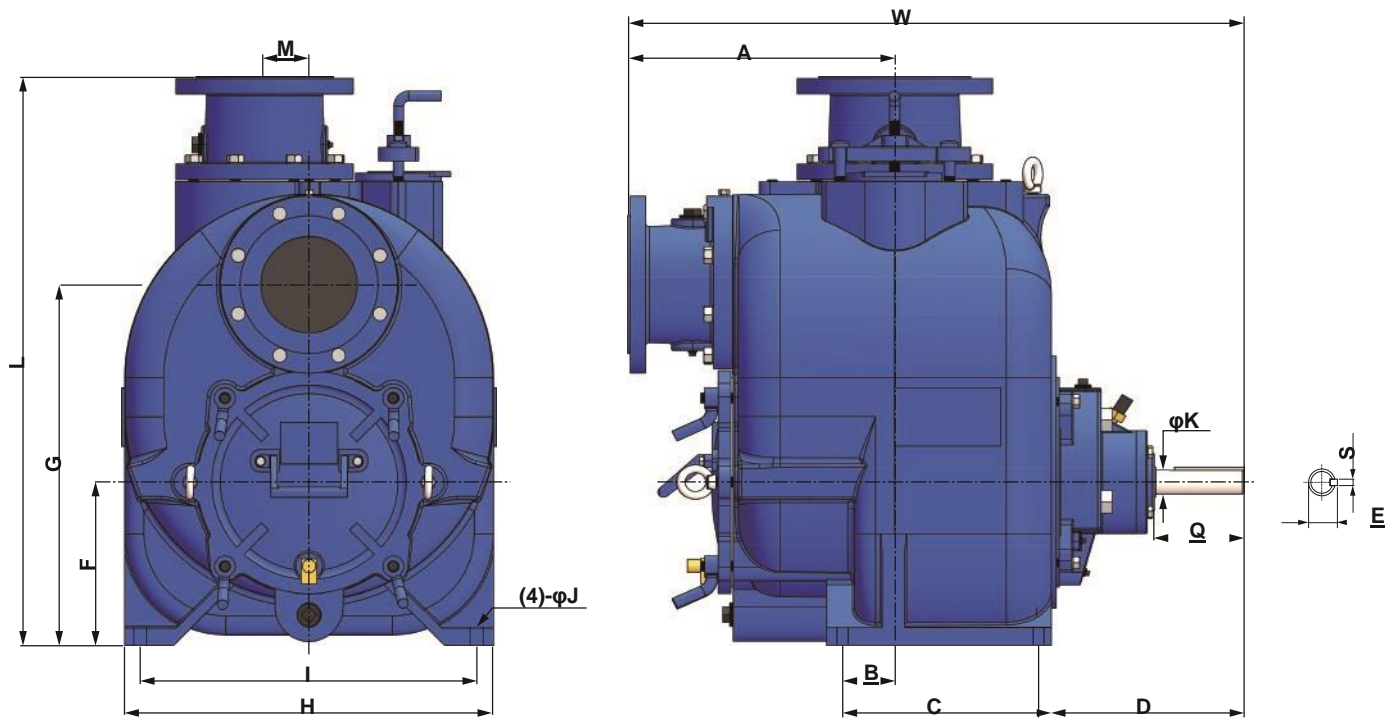

Pump Type	L	G	F	I	H	M	J	W	A	B	C	D	K	Q	S	E	Bare Pump Weight (kg)
TTSTP- 3	686.8	431.8	190.5	393.7	431.8	69.9	18.0	733.6	293.1	76.2	228.6	288.1	38.1	101.6	9.53	42.6	247
TTSTP- 4	742.3	495.3	222.3	457.2	505.0	69.9	18.0	813.6	316.6	76.2	279.4	293.8	38.1	127.0	9.53	42.6	324
TTSTP- 6	896.6	568.5	257.2	527.1	580.0	69.9	18.0	899.7	402.9	77.8	279.4	295.2	38.1	127.0	9.53	42.6	463
TTSTP- 8	1067.8	723.9	330.2	635.0	705.0	-	22.0	1028.8	411.4	101.6	304.8	414.2	44.5	168.0	9.53	48.9	730

TTSTP-10 OUTLINE DIMENSIONS [Unit: mm]

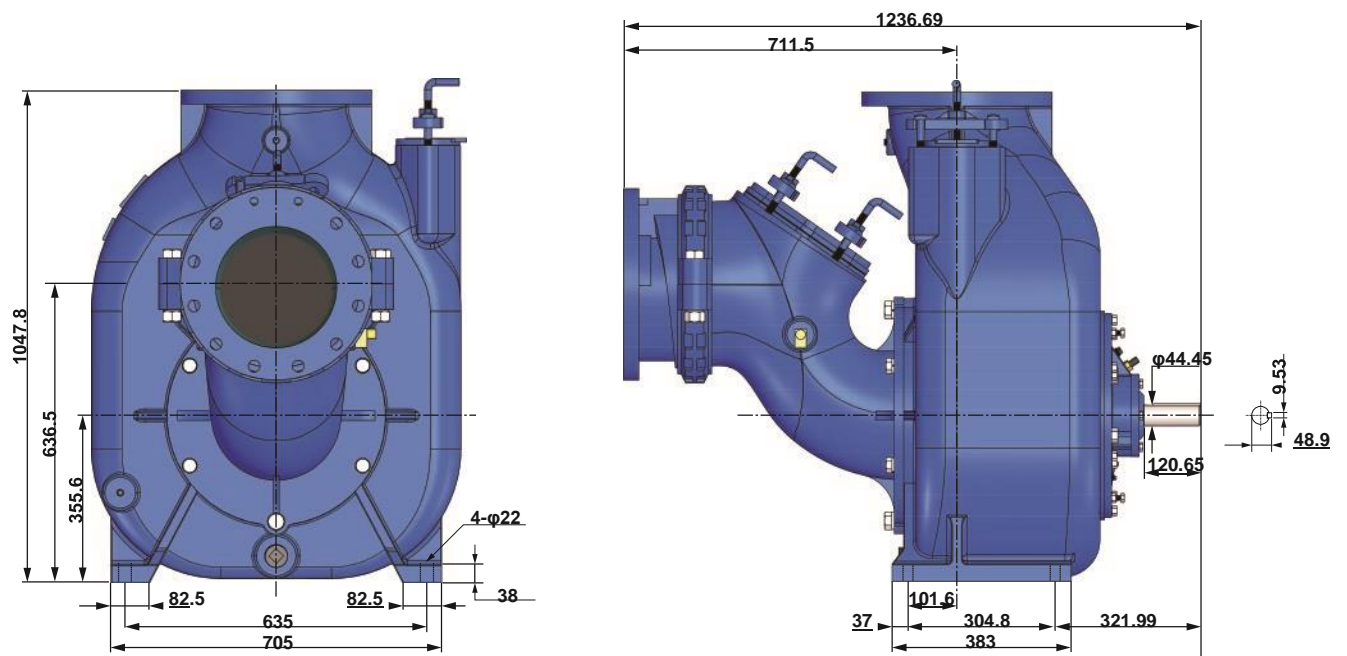

PERFORMANCE CHARTS

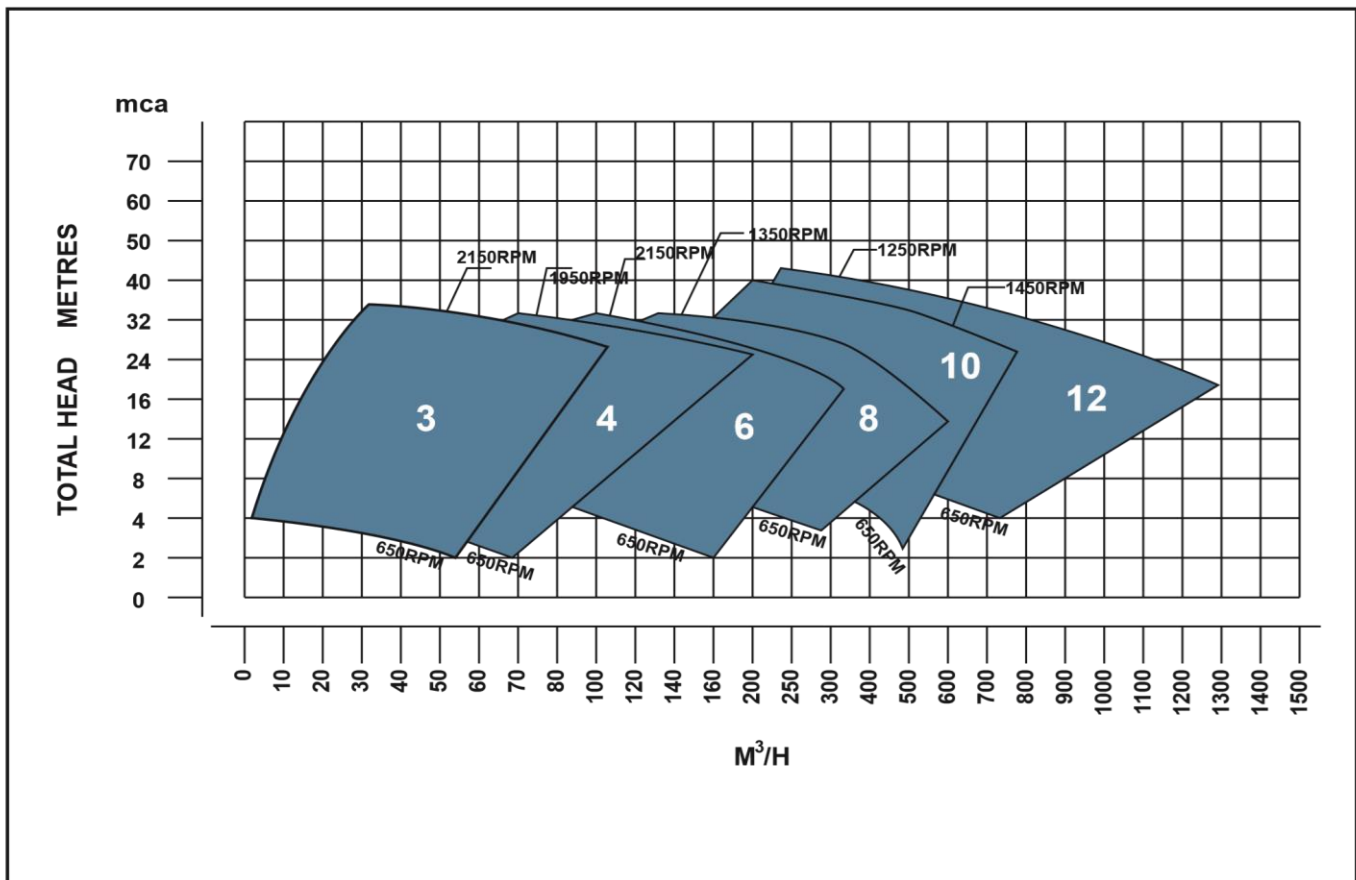

Contact: sales@titanpumpsinc.com
Phone: 713-283-7700. Fax: 713-283-7600
Visit Us: www.titanpumpsinc.com

